

## EUROPEAN STANDARD D-SUB. FEMALE CONNECTOR RIGHT ANGLE TYPE (9.4MM)

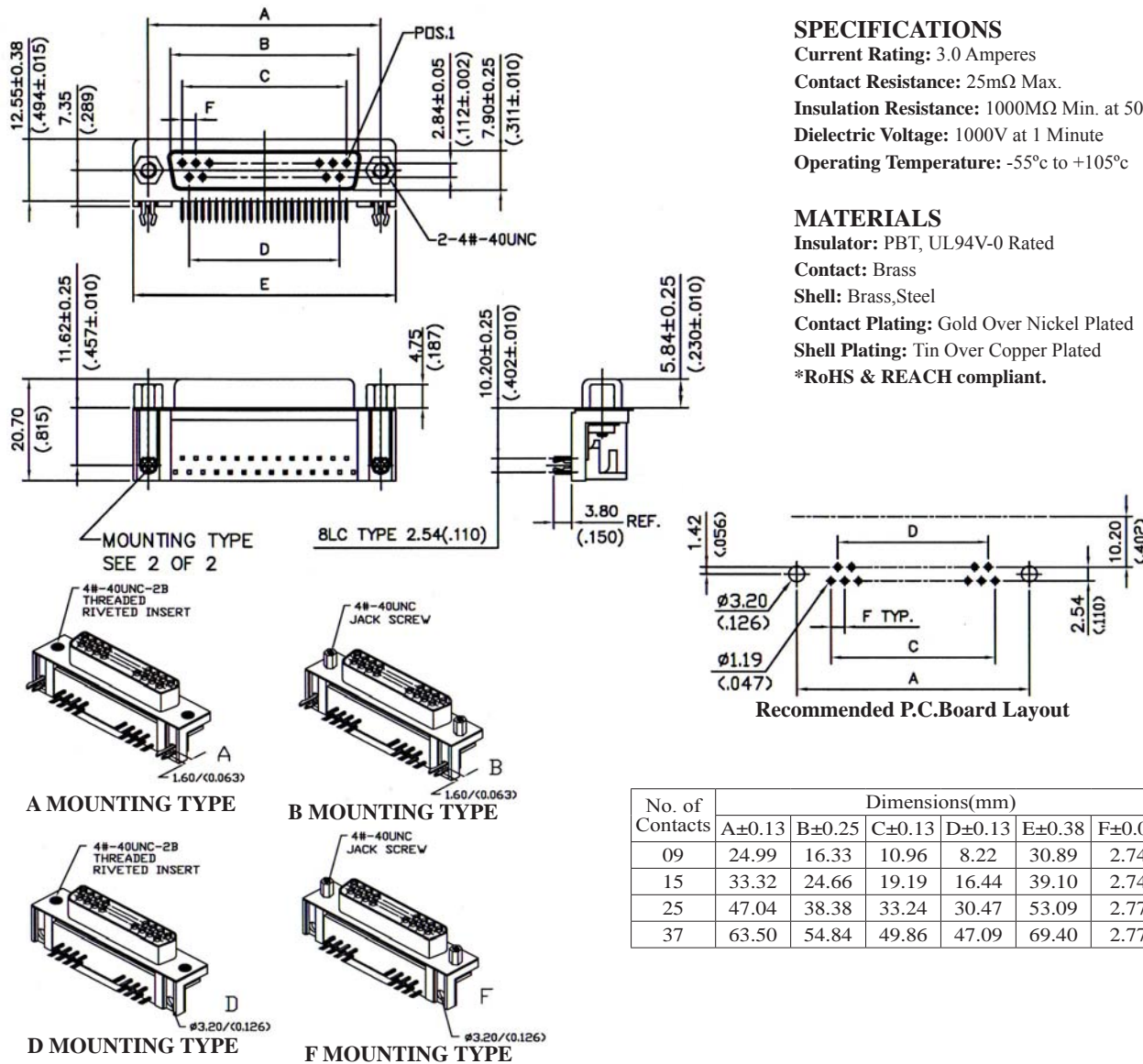

### ORDERING INFORMATION:

P/N 5 2 7 2 -  $\frac{x}{I} \frac{x}{2}$

1. NO. OF CONTACTS:  
09, 15, 25, 37
2. MOUNTING TYPE:  
 "A" WITH BOARDLOCK GROUNDING BRACKET & WITH UNC4-40 THREADED RIVETED INSERT  
 "B" WITH BOARDLOCK GROUNDING BRACKET & SCREW LOCK  
 "D" WITH Ø3.2MM MOUNTING HOLE & UNC4-40 THREADED RIVETED INSERT  
 "F" WITH Ø3.2MM MOUNTING HOLE & WITH SCREW LOCK

**NOTE: THE SPECIFICATION CONFORMS TO EUROPEAN STANDARD:**

- \* CONTACT EXTENTION: 9.4MM
- \* CONTACT CENTER SPACING: 2.54MM