

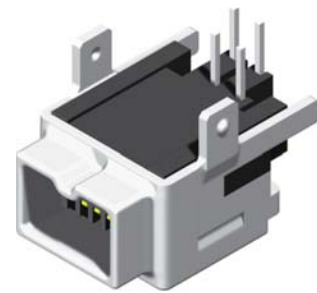

**IEEE1394 Female Dip 90 4P**

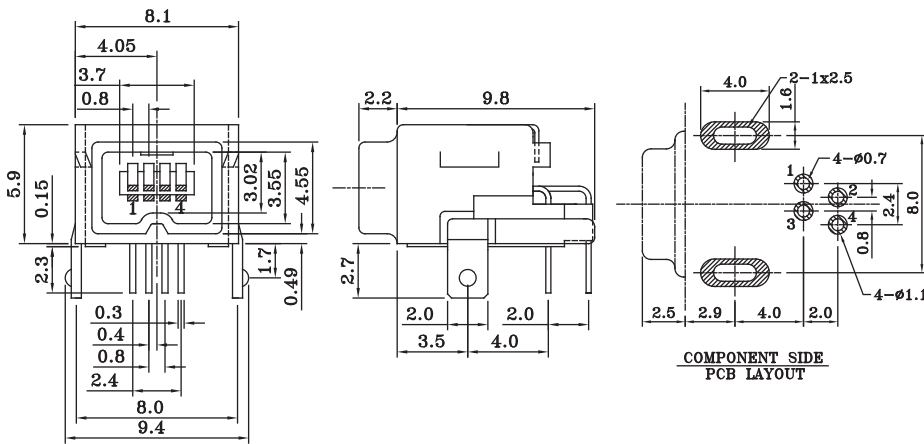

No.	Name	Qty	Material	Remarks & Thickness	Finish
1	Housing	1	Nylon 9T G.F		Black
2	Pin Term.	4	Phos. Bronze T=0.25	Gold:30u"; Ni:40-60u"; TIN:120u" (100% pure Tin of lead free plating)	Gold/Tin Plated
3	Front Shell	1	Steel T=0.5	Ni:2-3u	Nickel Plated
4	Rear Shell	1	Brass T=0.2	Ni:2-3u	Nickel Plated

**Part No.:IEEE-1394R-4L2-U**

**IEEE1394 Female SMT 90 6P**

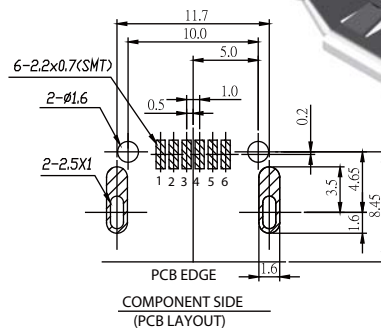
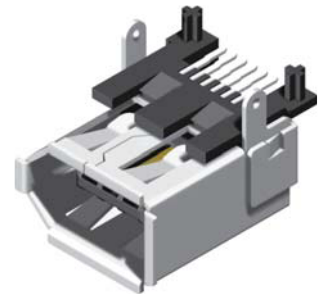
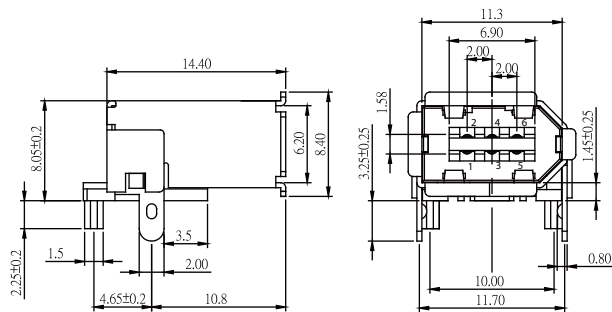

No.	Name	Qty	Material	Remarks & Thickness	Finish
1	Housing	1	Nylon 9T G.F		Black
2	Pin Terminal	6	Brass T=0.25	Gold:30u"; Ni:40-60u"; TIN:120u" (100% pure Tin of lead free plating)	Gold/Tin Plated
3	Shell	1	Brass T=0.4		Nickel Plated

**Part No.:IEEE-1394MR-6-U**

**IEEE1394 Female Dip 90 6P**

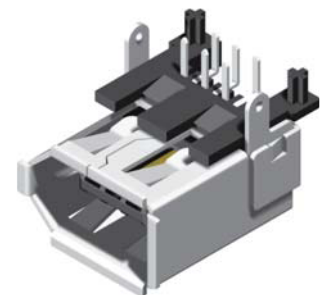
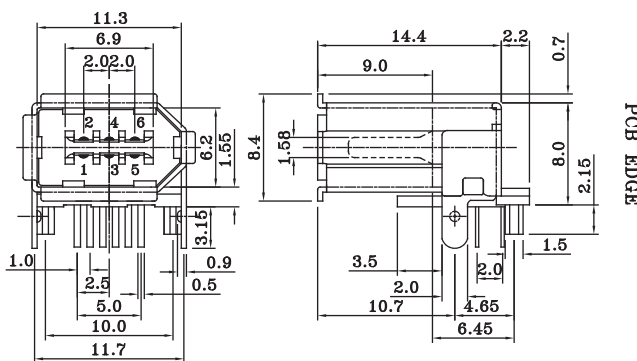

No.	Name	Qty	Material	Remarks & Thickness	Finish
1	Housing	1	Nylon 9T G.F		Black
2	Pin Terminal	6	Brass T=0.25	Gold:30u"; Ni:40-60u"; TIN:120u" (100% pure Tin of lead free plating)	Gold/Tin Plated
3	Shell	1	Brass T=0.4		Nickel Plated

**Part No.:IEEE-1394R-6-U**