

SIDE ENTRY MODULAR SMT JACK 8P PROFILE=11.75MM (FULLY SHIELDED)

SPECIFICATIONS

Insulation Resistance: 500MΩ Min.
Contact Resistance: 20mΩ Max.
Rating Current: 1.5A Max.
Rating Voltage: 120V AC.
Dielectric Voltage: 1000 Vrms 60 Sec. Min.
Temperature Range: -40°C / +85°C
Durability: 500 Mating cycles Min.

MATERIALS

Housing: Nylon (UL 94V-0)
Soldering Temperature: 260°C
Color: Black
Spring Wire: Phosphor Bronze
 Gold plating Over Nickel
All materials must be RoHS compliant.

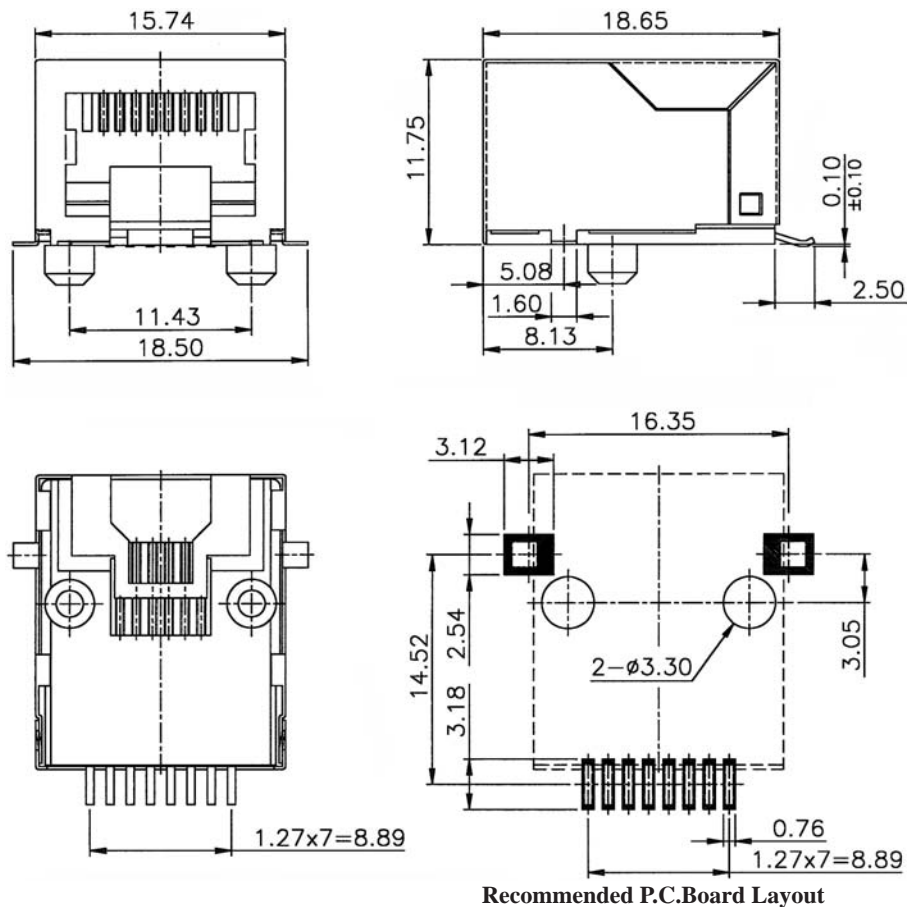

ORDERING INFORMATION:

P/N MJ 19 - $\frac{x}{1} \frac{x}{2} \frac{x}{3} B - x$

1. NO. OF POSITIONS & CONTACTS:
 "88" 8P8C
 "84" 8P4C
2. CONTACT FINISH:
 "A" 6 MICROINCH GOLD
 "B" 15 MICROINCH GOLD
 "C" 30 MICROINCH GOLD
 "D" 50 MICROINCH GOLD
3. PACKAGE OPTION:
 " " TRAY
 "R" TAPE & REEL

SIDE ENTRY MODULAR SMT JACK 10P PROFILE=11.75MM (FULLY SHIELDED)

SPECIFICATIONS

Insulation Resistance: 500MΩ Min.
Contact Resistance: 20mΩ Max.
Rating Current: 1.5A Max.
Rating Voltage: 120V AC.
Dielectric Voltage: 1000 Vrms 60 Sec. Min.
Temperature Range: -40°C / +85°C
Durability: 500 Mating cycles Min.

MATERIALS

Housing: Nylon (UL 94V-0)
Soldering Temperature: 260°C
Color: Black
Spring Wire: Phosphor Bronze
 Gold plating Over Nickel
All materials must be RoHS compliant.

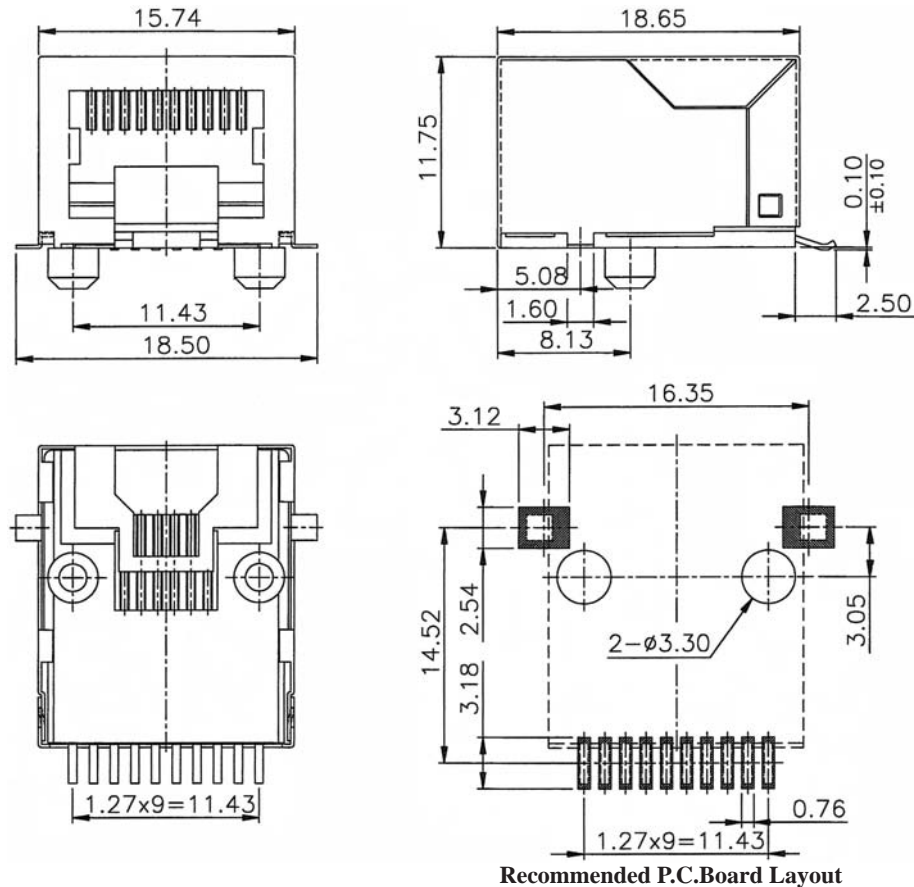

ORDERING INFORMATION:

P/N MJ 19 - $\frac{x}{1}$ $\frac{x}{2}$ B - $\frac{x}{3}$

1. NO. OF POSITIONS & CONTACTS:
 "00" 10P10C
 "08" 10P8C
2. CONTACT FINISH:
 "A" 6 MICROINCH GOLD
 "B" 15 MICROINCH GOLD
 "C" 30 MICROINCH GOLD
 "D" 50 MICROINCH GOLD
3. PACKAGE OPTION:
 " " TRAY
 "R" TAPE & REEL