

SIDE ENTRY 2-PORT MODULAR PCB JACK 8P PROFILE=11.50MM (UNSHIELDED)

SPECIFICATIONS

Insulation Resistance: 500MΩ Min.
Contact Resistance: 20mΩ Max.
Rating Current: 1.5A Max.
Rating Voltage: 120V AC.
Dielectric Voltage: 1000 Vrms 60 Sec. Min.
Temperature Range: -40°C / +85°C
Durability: 500 Mating cycles Min.

MATERIALS

Housing: PBT Glass Filled (UL 94V-0)
Soldering Temperature: 235°C
Color: Black
Spring Wire: Phosphor Bronze
 Gold plating Over Nickel
All materials must be RoHS compliant.

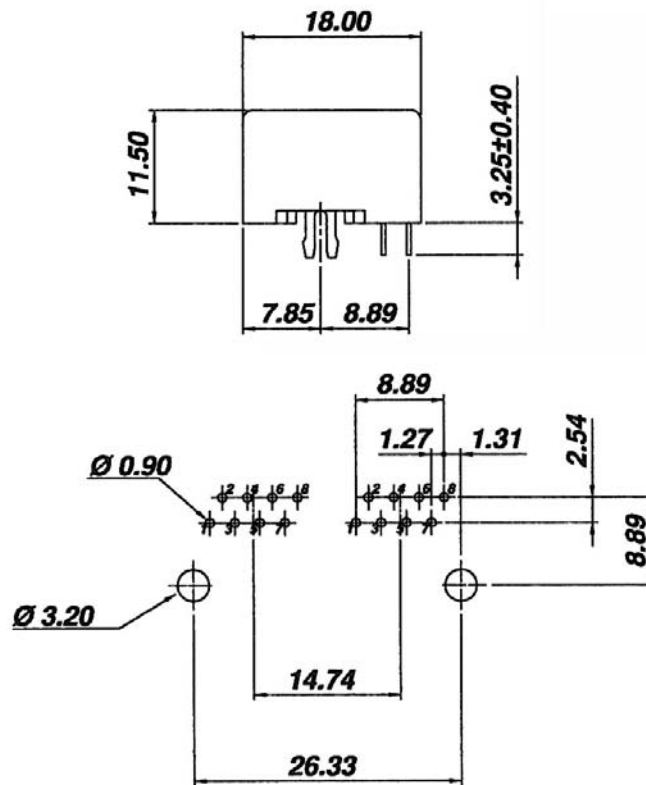
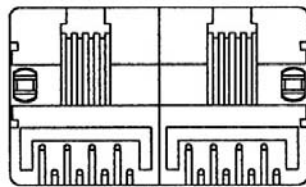
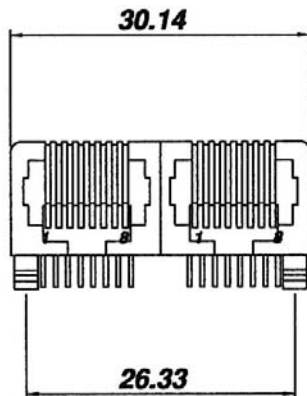

Recommended P.C.Board Layout
(TOP VIEW)

ORDERING INFORMATION:

P/N MJ6N - $\frac{88}{1} \times \frac{B}{2} \frac{02}{3}$

1. NO. OF POSITIONS & CONTACTS:
"88" 8P8C
2. CONTACT FINISH:
"A" 6 MICROINCH GOLD
"B" 15 MICROINCH GOLD
"C" 30 MICROINCH GOLD
"D" 50 MICROINCH GOLD
3. NO. OF PORTS:
02

NOTE: MJ6NHT-88xB02 for High Temp. Version

SIDE ENTRY 4-PORT MODULAR PCB JACK 8P PROFILE=11.50MM (UNSHIELDED)

SPECIFICATIONS

Insulation Resistance: 500MΩ Min.
Contact Resistance: 20mΩ Max.
Rating Current: 1.5A Max.
Rating Voltage: 120V AC.
Dielectric Voltage: 1000 Vrms 60 Sec. Min.
Temperature Range: -40°C / +85°C
Durability: 500 Mating cycles Min.

MATERIALS

Housing: PBT Glass Filled (UL 94V-0)
Soldering Temperature: 235°C
Color: Black
Spring Wire: Phosphor Bronze
 Gold plating Over Nickel
All materials must be RoHS compliant.

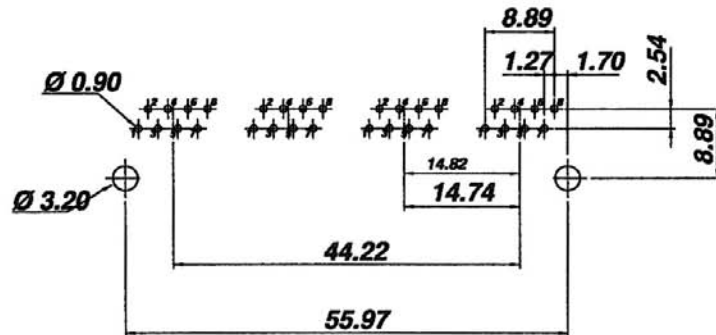
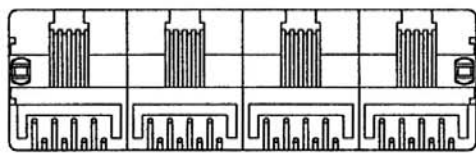
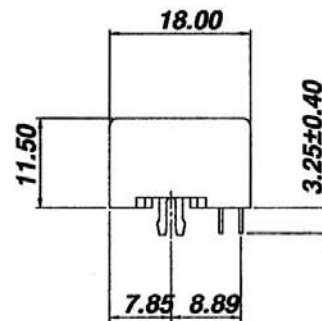
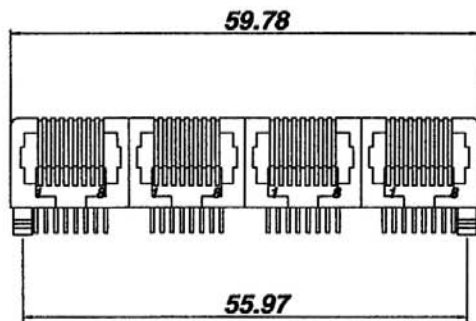

Recommended P.C.Board Layout
(TOP VIEW)

ORDERING INFORMATION:

P/N MJ6N - $\frac{88}{1} \times \frac{B}{2} \frac{04}{3}$

1. NO. OF POSITIONS & CONTACTS:
"88" 8P8C
2. CONTACT FINISH:
"A" 6 MICROINCH GOLD
"B" 15 MICROINCH GOLD
"C" 30 MICROINCH GOLD
"D" 50 MICROINCH GOLD
3. NO. OF PORTS:
04

NOTE: MJ6NHT-88xB04 for High Temp. Version

SIDE ENTRY 6-PORT MODULAR PCB JACK 8P PROFILE=11.50MM (UNSHIELDED)

SPECIFICATIONS

Insulation Resistance: 500MΩ Min.
Contact Resistance: 20mΩ Max.
Rating Current: 1.5A Max.
Rating Voltage: 120V AC.
Dielectric Voltage: 1000 Vrms 60 Sec. Min.
Temperature Range: -40°C / +85°C
Durability: 500 Mating cycles Min.

MATERIALS

Housing: PBT Glass Filled (UL 94V-0)
Soldering Temperature: 235°C
Color: Black
Spring Wire: Phosphor Bronze
 Gold plating Over Nickel
All materials must be RoHS compliant.

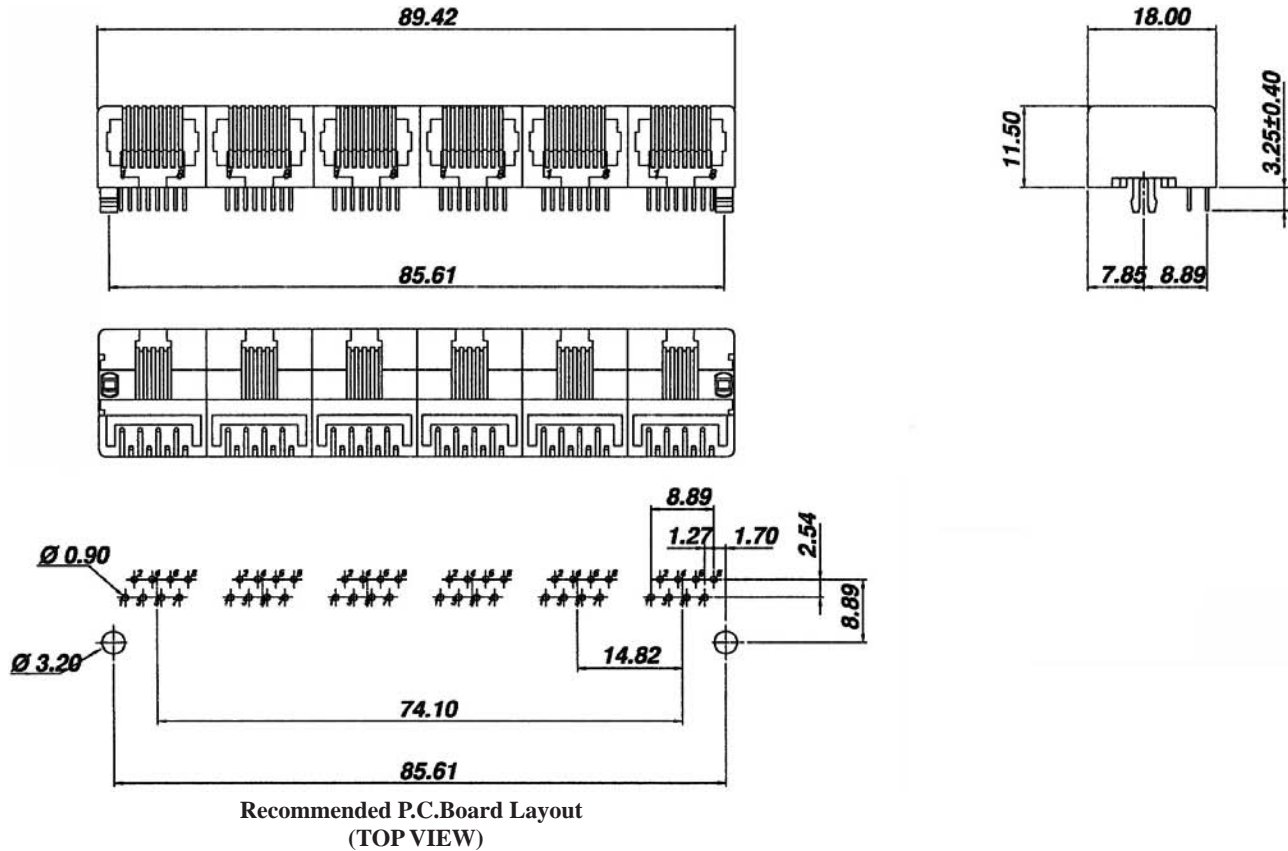

ORDERING INFORMATION:

P/N MJ6N - $\frac{88}{1} \times \frac{B}{2} \frac{06}{3}$

1. NO. OF POSITIONS & CONTACTS:
"88" 8P8C
2. CONTACT FINISH:
"A" 6 MICROINCH GOLD
"B" 15 MICROINCH GOLD
"C" 30 MICROINCH GOLD
"D" 50 MICROINCH GOLD
3. NO. OF PORTS:
06

NOTE: MJ6NHT-88xB06 for High Temp. Version

SIDE ENTRY 2-PORT MODULAR PCB JACK 6P PROFILE=11.70MM (UNSHIELDED)

SPECIFICATIONS

Insulation Resistance: 500MΩ Min.
Contact Resistance: 20mΩ Max.
Rating Current: 1.5A Max.
Rating Voltage: 120V AC.
Dielectric Voltage: 1000 Vrms 60 Sec. Min.
Temperature Range: -40°C / +85°C
Durability: 500 Mating cycles Min.

MATERIALS

Housing: PBT Glass Filled (UL 94V-0)
Soldering Temperature: 235°C
Color: Black
Spring Wire: Phosphor Bronze
 Gold plating Over Nickel
All materials must be RoHS compliant.

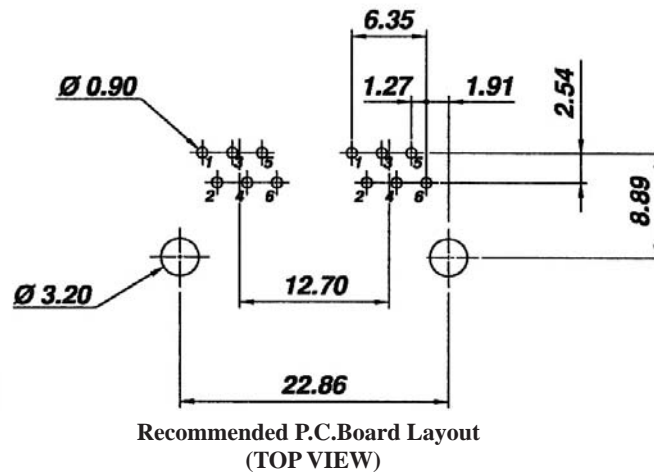
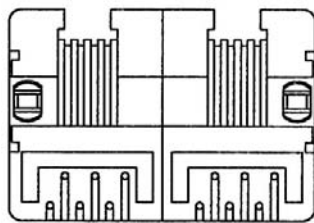
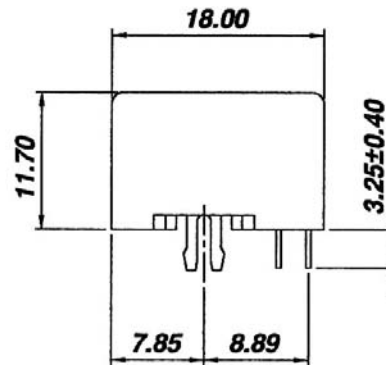
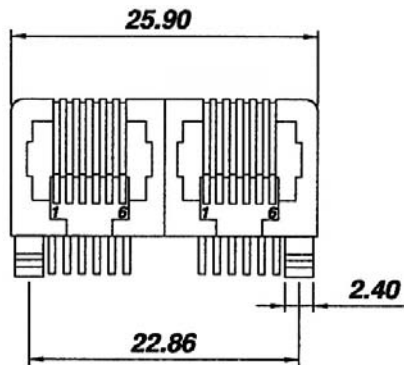

ORDERING INFORMATION:

P/N MJ6N - $\frac{x}{1} \frac{x}{2} \frac{x}{3} B \frac{0}{2}$

- NO. OF POSITIONS & CONTACTS:
 "66" 6P6C
 "64" 6P4C
- CONTACT FINISH:
 "A" 6 MICROINCH GOLD
 "B" 15 MICROINCH GOLD
 "C" 30 MICROINCH GOLD
 "D" 50 MICROINCH GOLD
- NO. OF PORTS:
 02

NOTE: P/N MJ6NHT-6xxB02 for High Temp. Version

SIDE ENTRY 4-PORT MODULAR PCB JACK 6P PROFILE=11.70MM (UNSHIELDED)

SPECIFICATIONS

Insulation Resistance: 500MΩ Min.
Contact Resistance: 20mΩ Max.
Rating Current: 1.5A Max.
Rating Voltage: 120V AC.
Dielectric Voltage: 1000 Vrms 60 Sec. Min.
Temperature Range: -40°C / +85°C
Durability: 500 Mating cycles Min.

MATERIALS

Housing: PBT Glass Filled (UL 94V-0)
Soldering Temperature: 235°C
Color: Black
Spring Wire: Phosphor Bronze
 Gold plating Over Nickel
All materials must be RoHS compliant.

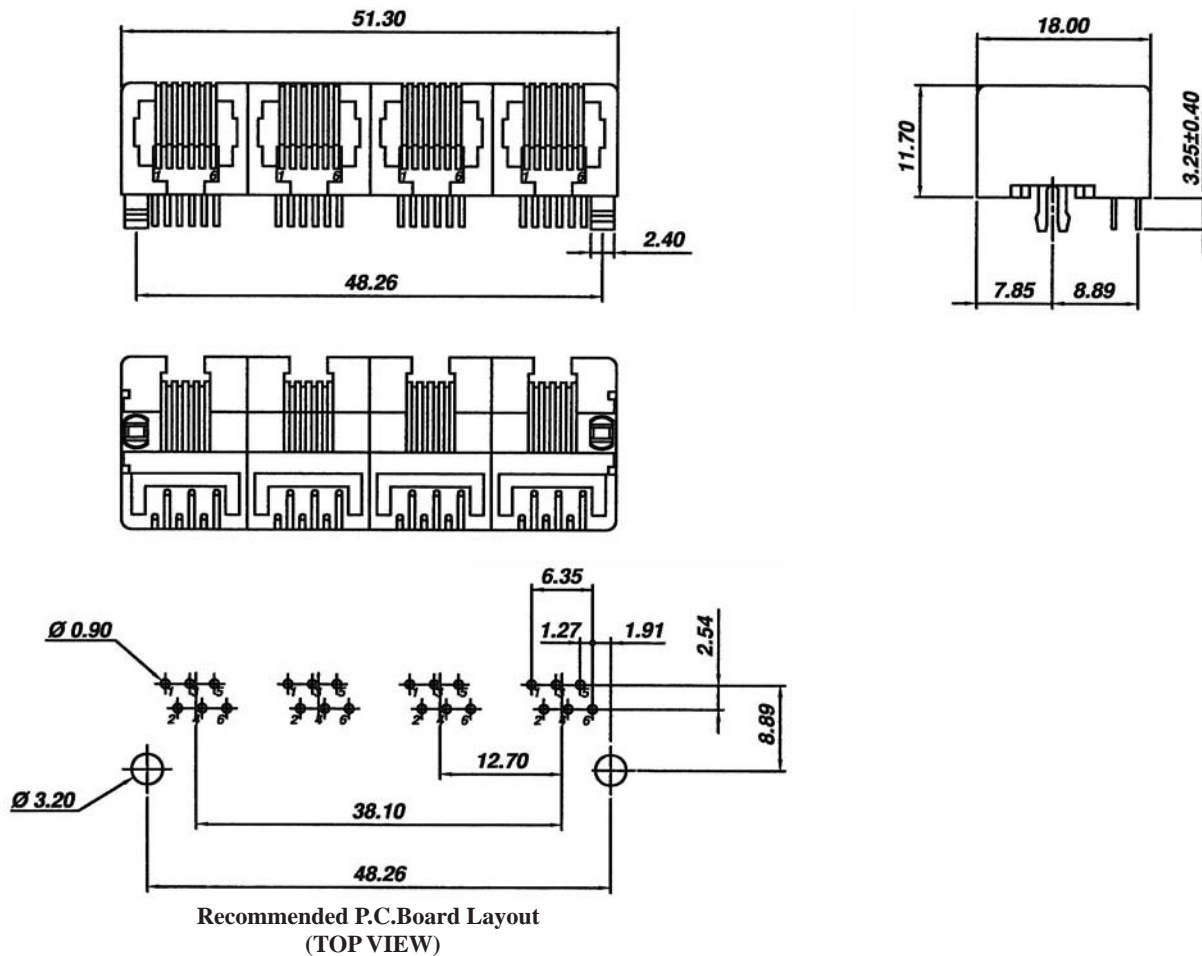

ORDERING INFORMATION:

P/N MJ6N - $\frac{x}{1} \frac{x}{2} \frac{x}{3} B 04$

1. NO. OF POSITIONS & CONTACTS:
 "66" 6P6C
 "64" 6P4C
2. CONTACT FINISH:
 "A" 6 MICROINCH GOLD
 "B" 15 MICROINCH GOLD
 "C" 30 MICROINCH GOLD
 "D" 50 MICROINCH GOLD
3. NO. OF PORTS:
 04

NOTE: P/N MJ6NHT-6xxB04 for High Temp. Version

SIDE ENTRY 6-PORT MODULAR PCB JACK 6P PROFILE=11.70MM (UNSHIELDED)

SPECIFICATIONS

Insulation Resistance: 500MΩ Min.
Contact Resistance: 20mΩ Max.
Rating Current: 1.5A Max.
Rating Voltage: 120V AC.
Dielectric Voltage: 1000 Vrms 60 Sec. Min.
Temperature Range: -40°C / +85°C
Durability: 500 Mating cycles Min.

MATERIALS

Housing: PBT Glass Filled (UL 94V-0)
Soldering Temperature: 235°C
Color: Black
Spring Wire: Phosphor Bronze
 Gold plating Over Nickel
All materials must be RoHS compliant.

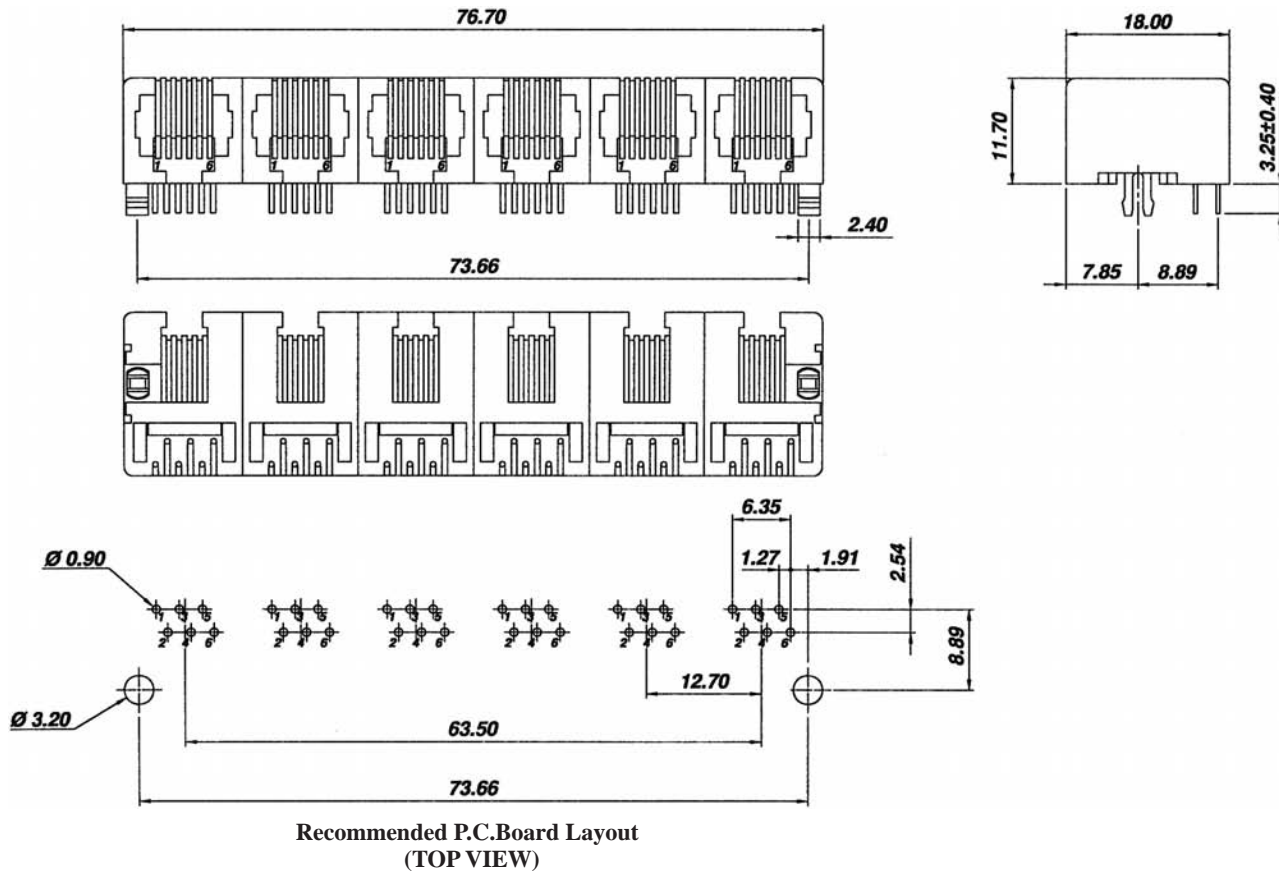

ORDERING INFORMATION:

P/N MJ6N - $\frac{x}{1} \frac{x}{2} \frac{x}{3} B \frac{0}{3}$

1. NO. OF POSITIONS & CONTACTS:
 "66" 6P6C
 "64" 6P4C
2. CONTACT FINISH:
 "A" 6 MICROINCH GOLD
 "B" 15 MICROINCH GOLD
 "C" 30 MICROINCH GOLD
 "D" 50 MICROINCH GOLD
3. NO. OF PORTS:
 06

NOTE: P/N MJ6NHT-6xxB06 for High Temp. Version