

MATERIAL SPECIFICATION:

1. HOUSING:LCP PLASTIC(UL94V-0)
2. CONTACT:PHOSPHOR BRONZE
3. SHELL:BRASS

ELECTRICAL PERFORMANCE

1. RATED VOLTAGE(MAX.):30V AC/DC
2. RATED CURRENT(MAX.):1.0A AC/DC
3. DIELECTRIC STRENGTH:100V AC FOR 1 MINUTE BETWEEN ADJACENT TERMINAL, NO BREAKDOWN
4. INSULATION RESISTANCE:100 MEGOHMS MIN. 100V DC FOR 1 MINUTE BETWEEN ADJACENT TERMINAL
5. CONTACT RESISTANCE:50 MILLIOHM MAX.
6. OPERATING TEMPERATURE:-25° to +80°

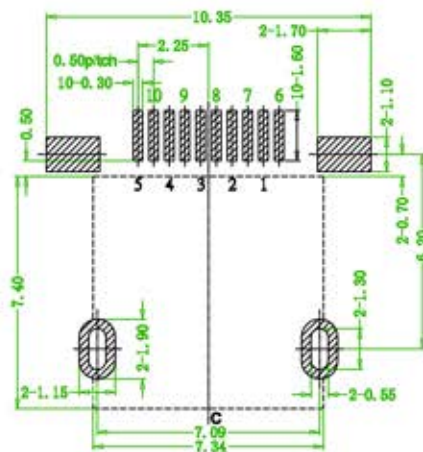
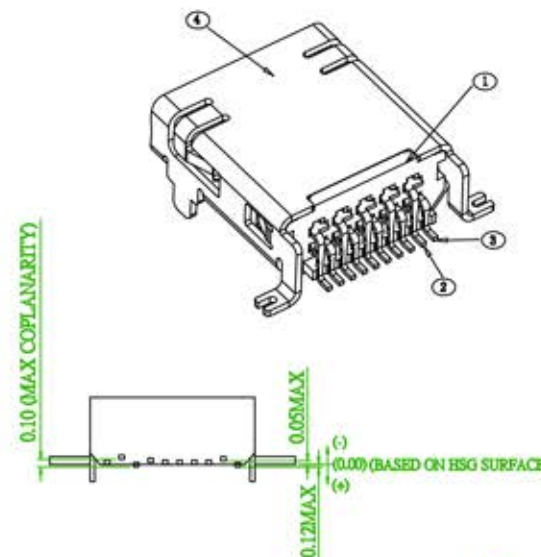
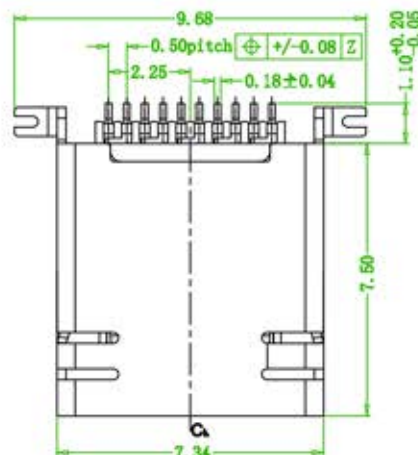

Recommended P.C.B Layout(Top Side)
Tolerance=±0.05

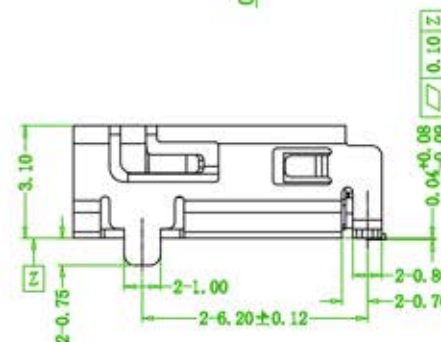
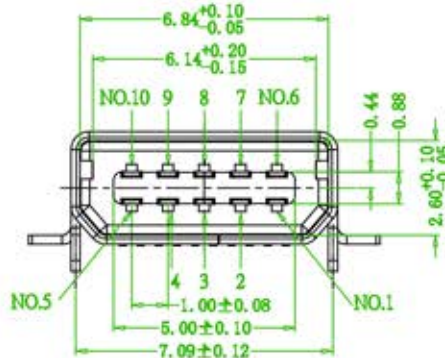

NO.	Name	Qty	Material
1	HOUSING	1	HIGH TEMPERATURE THERMOPLASTIC. (UL94-V0).BLACK
2	CONTACT 3	5	COPPER ALLOY T=0.15mm UNDER PLATED 50u" MIN. NICKEL OVER ALL
3	CONTACT 4	5	COPPER ALLOY T=0.15mm UNDER PLATED 50u" MIN. NICKEL OVER ALL

Part No.	Part No.
MUSB-F10M-U	Gold Flash
MUSB-F10MGF-U	Gold 15u"
MUSB-F10M-2.0-U	Gold 30u"

	品名 TITLE	MINI USB 10P FEMALE SMT TYPE				
	品號 PART NO.	MUSB-F10M-U			日期 DATE	2010/02/02
	圖號 DRAWING NO.	MUSB-F10M-U	版本 REV.	A	繪圖 DRAWN	Sam
	客戶品號 CUSTOMER P/N		比例 SCALE	FREE	核對 CHECKED	Edward
	公差 TOLERANCE	.X ±0.30 .XX ±0.20	單位 UNIT	mm	核准 APPROVED	James

AREA	REV.	DESCRIPTION	DATE