

RS232 1Kanal Data Line Powered DCE

1 General

This device is a modem for asynchronous data transmission in full-duplex mode. Drawing all necessary operating power from the RS232 Interface, the system supports data rates to 120kBit/s and link length up to 100m using low cost 1mm Polymer Optical Fiber (POF) (660nm version). According to the used multimode fiber optic cable, data link length's up to 1000m are possible (850nm version).

2 Applications

Due to the max. data rate of 120 kBit/s, the max. link length of 1000m between 2 stations and the protocol free operation the modem can be used in many applications:

- existing electrical RS232 Systems can be extended up to 1000m link lengths
- Interference-free data transmission in EMI-loaded area
- electrical isolation between RS232 interaces

3 Block diagramm

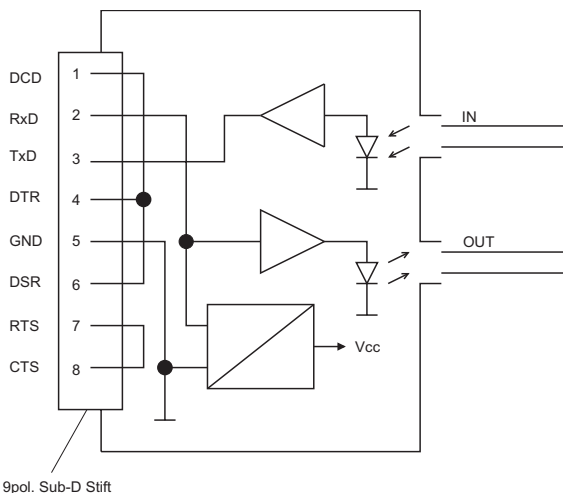

9pol. Sub-D Stift

Pic. 2 Block diagramm

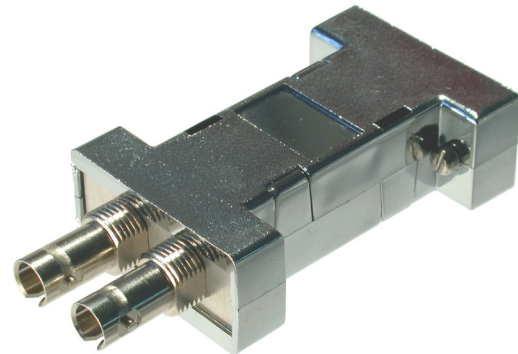

Pic. 1 Interface

4 Features

- 1Channel RS232 - FO Transceiver
- Full-Duplex Data Transmission
- 120 kBit/s Data rate
- Protocol-transparent
- 9-way Sub-D Connector Male
- F-SMA, F-ST or other standardized optical connectors
- Metalized plastic case
- Data line powered

5 Ordering information

Specification

660 nm / F-SMA
 660 nm / F-ST
 850 nm / F-SMA
 850 nm / F-ST

Part number

901SV232C6091
 901SV232C6092
 901SV232C8091
 901SV232C8092

RS232 1Kanal Data Line Powered DCE

6 Options _____

On request the modem can be ordered with following options:

- latching element for rail mounting
- inverted optical signal (see 8 Operation)
- F-ST, F-SMA or other standardized optical connectors.

7 CE-Declaration of Conformity _____

The RS232 1Channel modem meets the basic requirements according to Article 4 and Appendix III of Directive 89/336/EWG:

Electromagnetic Interference (EMI).

The modem complies with the followings standards:

- EN 55022 or EN 50081-1
- EN 55024 or EN 50082-1
- EN 50082-2 (Industrial use)

Stray radiation:

30MHz to 230MHz - QP <30dB μ V/m

230MHz to 1000MHz - QP <37dB μ V/m

Susceptibility to interference:

80MHz bis 1000MHz mit 10V/m, 1kHz, AM

8 Functioning _____

The RS232 1Channel Modem is a code transparent electro-optical transceiver.

Incoming data at the electrical interface is converted into optical signals and transmitted by optical fiber.

The optical receiver at the other side recovers the optical signal to the corresponding RS232 format.

The RS232-FO conversion takes place acc. to following scheme:

$U_{IN} \geq +3V = '0' \Rightarrow \text{opt. Out=On}$

$U_{IN} \leq -3V = '1' \Rightarrow \text{opt. Out=Off}$

For applications requiring an inverted optical signal, appropriate modems can be ordered (optional).

9 Power supply _____

The modem draws all necessary operating power from the RxD data line.

Therefore no external power supply is needed.

For proper operation it is must be guaranteed that the application line drivers are in accordance with the EIA-RS232-C standard and that the RxD application line driver is not turned off (into high-Z) during transmission idle.

Pic. 3 shows the modem current consumption subject to line driver output voltage on RxD line:

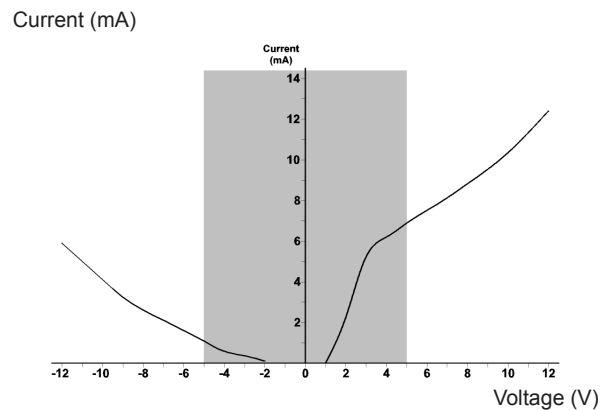

Pic. 3 Current consumption vs. driver output voltage

Within the shaded area modem function is not guaranteed, because optical output power and optical sensitivity drops to undefined levels.

Pic. 4 shows the relative optical output power (P_{OUTrel}) subject to line driver voltage on TxD.

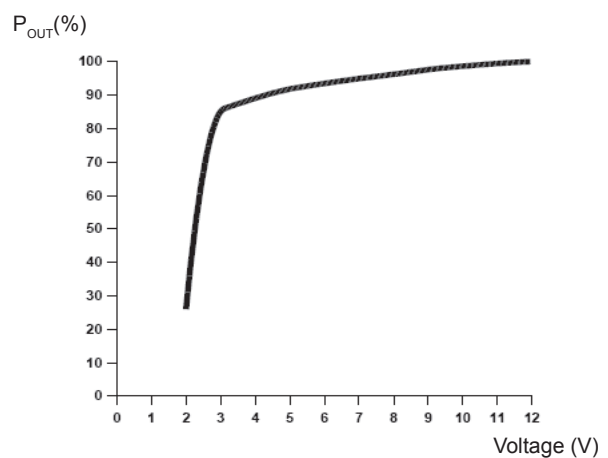

Pic. 4 Rel. optical power output vs.driver voltage



RS232 1Kanal Data Line Powered DCE

10 Installation

- Make sure that all equipment is off power to avoid electrical damage during installaion
- Connect the Fiber-Optic-Interface to the Com.-Interface
- Connect the FO cable with the Fiber-Optic Interface (see Pic.5)



Pic. 5 Installation

11 EIA-RS232 Standard

The full declaration of the RS232 Interface and the meaning of the signal names and symbols can be derived from the EIA RS232-C standard. An agreed case is that RS232 devices are separated into two classes: DTE (Data Terminal Equipment exp. Computers) and DCE (Data Communication Equipment e.g. Modems). The standard describes the 25-way Sub-D, however the 9-way Sub-D is now more used.

DCE = Sub-D female
DTE = Sub-D male

Example 1: Pinout 9-way Sub-D

Pin	Name	DCE	DTE
1	DCD	Output	Input
2	RxD	Output	Input
3	TxD	Input	Output
4	DTR	Input	Output
5	GND	Ground	Ground
6	DSR	Output	Input
7	RTS	Input	Output
8	CTS	Output	Input
9	RI	Output	Input

Example 2: Pinout 25-way Sub-D

Pin	Name	DCE	DTE
1	CG	Earth	Earth
2	TxD	Input	Output
3	RxD	Output	Input
4	RTS	Input	Output
5	CTS	Output	Input
6	DSR	Output	Input
7	GND	Ground	Ground
8	DCD	Output	Input
12	DCD2	Output	Input
13	CTS2	Output	Input
14	TXD2	Input	Output
15	TxC	Output	Input
16	RxD2	Output	Input
17	RxC	Output	Input
19	RTS2	Input	Output
20	DTR	Input	Output
22	RI	Output	Input
23	DRS	I/O	I/O
24	TxC	Input	Output
25	BUSY	Output	Input

12 Sub-D Pin Out

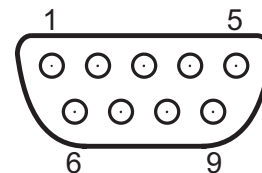

Pic. 6 Sub-D male connector

PIN Nr.	Name	Funktion
1	DCD	shorted to DTR,DSR
2	RxD	Data IN
3	TxD	Data OUT
4	DTR	shorted DCD,DSR
5	GND	Ground
6	DSR	shorted to DCD,DTR
7	RTS	shorted to CTS
8	CTS	shorted to RTS
9	NC	not used

! Not used pins are without function and should be left open. !



RS232 1Kanal Data Line Powered DCE

13 Maximum ratings _____

Stresses beyond those listed under 'Maximum Ratings' may cause permanent damage to the modem. Above listed values are stress limits only and functional operation of the media converter at these conditions is not recommended. Exposure to maximum rating conditions for extended periods may affect the modem reliability.

TxD driver voltage _____ ±12V DC
 Output current _____ 10mA
 Storage temperature _____ -55...+125°C
 Operating temperature _____ -10...+85°C

14 Technical data _____

Data rate: 0 .. 120 kBit/s
Wavelength: 660nm, 850nm
opt. Interface: F-ST, F-SMA
max. link length: 300m min. GI-Fiber
 1000m typ. GI-Fiber
 60m min. PO-Fiber
 100m typ. PO-Fiber

Data format el.: RS232-C/V24
el. Interface: 9-way Sub-D male
Power supply: from data line
Current consumption: appr.10mA
Case: plastic, metalized
Dimensions: 66x34x17mm (L x W x H)
Protection class: IP40
Weight: 30g
Temperature range: 0 .. +80°C

15 Technical drawing _____

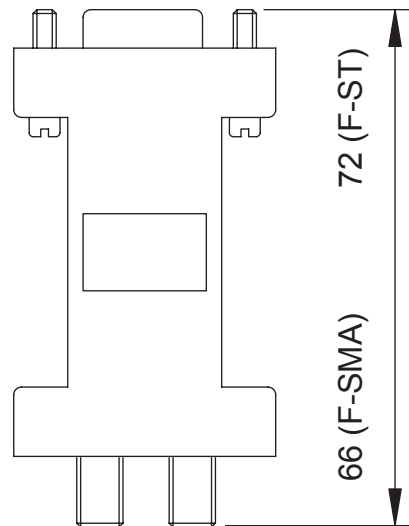
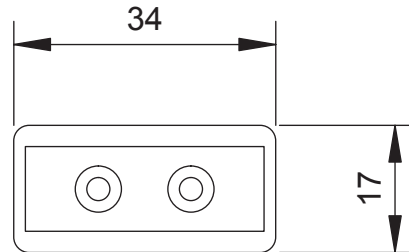

The information released by Ratioplast-Optoelectronics GmbH in this data sheet is believed to be accurate and reliable. However, no responsibility is assumed by Ratioplast-Optoelectronics GmbH for its use. Ratioplast-Optoelectronics GmbH reserves the right to change circuitry and specifications at any time without notification to the customer. ■